

HEATEC TEC-NOTE

Publication No. 6-05-166 Revised 6-13-05

Portable fuel tanks Volumes and Levels

SCOPE

This document applies to *portable* fuel tanks currently manufactured by Heatec (**Figure 1**). It defines *different* types of tank volumes and enables users to convert levels to volume.

VOLUME

This is the amount of space available for use. Most of the space inside a fuel tank is used to store liquid fuel. Some of the space is reserved for expansion and overflow control.

It is helpful to call different spaces by names that indicate their use. These names and definitions are presented below and shown in **Figure 2**.

In this document, volume is expressed in gallons. This is the most common unit of measure used for storage of fuel at HMA plants in the U.S.

NOMINAL VOLUME

This is the *approximate* capacity of a fuel tank. This amount is usually a number rounded off in thousands of gallons. It is useful in classifying tank sizes, but is not an exact indication of how much fuel can be stored in a tank.

GROSS VOLUME

This is the *total* amount of space *inside* a fuel tank. It includes the amount of space reserved for expansion and overflow control. Therefore, gross volume is usually more than the amount of fuel that will be stored in the tank.

NET VOLUME

This is the maximum amount of fuel that can be stored in a fuel tank with allowance for expansion. It is equal to the gross volume less the space for expansion and overflow control. It ignores other components such as vent/overflow piping, fill piping, internal fuel preheaters and mixer impellers because the space they occupy is not usually significant.

RESERVED SPACE

This is empty space in the top of the tank reserved for overflow control. *It also allows for thermal expansion of the fuel.* This space normally extends downward several



Figure 1. Heatec portable fuel tank .

FIGURE 2. VOLUMES* (GALLONS)

PORTABLE FUEL TANKS WITH SINGLE WALLS

Nominal volume	10,000	15,000	20,000	25,000
Gross Volume	10,445	15,627	20,809	25,991
Reserved space volume**	182	272	362	452
Net volume	10,263	15,355	20,447	25,539

PORTABLE FUEL TANKS WITH DOUBLE WALLS

Nominal volume	10,000	15,000	20,000	25,000
Gross Volume	10,649	16,524	22,399	28,274
Reserved space volume**	199	309	419	529
Net volume	10,450	16,215	21,980	27,745

*The volumes shown here apply only to the current line of Heatec tanks.

** Equal to 6 inches from the crest of the tank.

inches below the inside crest of the tank. This space *varies*. It is *not* included in net volumes shown in **Figure 2**.

Optional overflow controls set off an alarm when the fuel reaches a specified level. The alarm is usually a horn or a flashing light. On some tanks the control shuts off the fuel unloading pump. The amount of space reserved for overflow control depends on the devices used and how they are set up. On some tanks, overflow control is achieved using a float switch. On other tanks, overflow control employs a pressure transmitter and a Honeywell controller. The controller is set to alarm when the level is several inches from the crest, usually 6 inches.

The reserved space in *your* tank may be different from the amount of space shown in **Figure 2**. The best way to make sure how much reserved space is used for overflow control in *your* tank is to fill the tank until the overflow control alarm is triggered. Then measure the vertical distance from the tank inside crest to the surface of the fuel. This is the amount of reserved space for *your* tank.

CONVERTING LEVELS TO VOLUMES

Figures 6 and 7 convert *levels* to *volume* or gallons of fuel thereby indicating how much fuel is stored in the tank.

Figure 6 is for single-wall tanks. **Figure 7** is for double-wall tanks. The internal dimensions of single-wall tanks differ from those of double-wall tanks as shown in **Figure 4**.

It is important to understand that the levels shown in Figures 6 and 7 refer to the height of the liquid above the inside bottom of the tank. You should also be aware that levels indicated by a *pressure transmitter* is the height of the liquid above the transmitter—**not** the bottom of the tank. The transmitter indicates zero when the fuel level is the same height as the transmitter. The transmitter is normally located 6 inches above the bottom of the tank. Thus, you must add 6 inches to the level indicated by the pressure transmitter to know the level above the bottom of the tank.

Do not confuse the levels above the bottom of the tank with levels found by extending a measuring tape through the manway at the top of the tank until it touches the fuel. That is a measure of empty space in the top of the tank—not how much fuel is in the tank.

However, you can use your measuring tape or “stick” measurement of empty space to determine the amount of fuel in your tank (see **Figure 3**). To do so, subtract your measurement from the inside diameter of the tank. (All current portable tanks with *single* walls have an inside diameter of 126 inches. All current portable tanks with *double* walls have an inside diameter of 120 inches.) This will give you the level of the fuel above the *bottom* of the tank. You can now use this level with **Figures 6 and 7** to determine the gallons of fuel stored in your tank.

Note: When making your measurement it is difficult to measure directly from the inside top surface of the tank to the fuel surface. It is much easier to measure from the bottom edge of the manway to the surface of the fuel. If you do that, you will need to make a separate measurement to determine

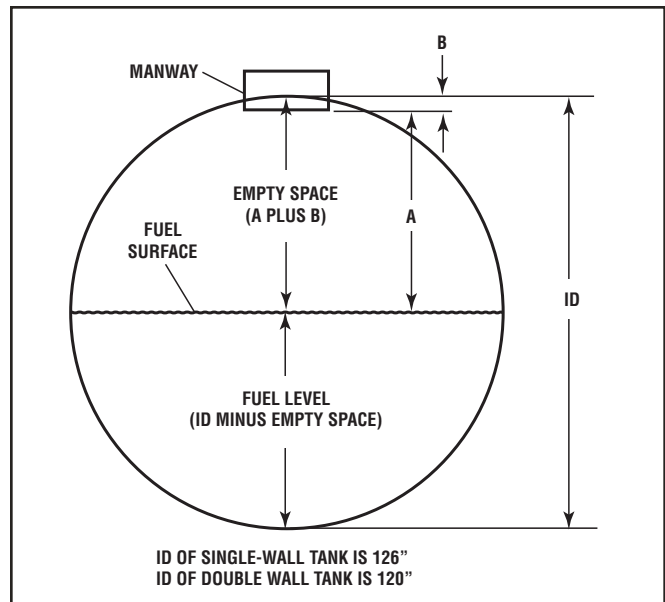

Figure 3. Making measurements from manway.

the distance from the edge of the manway to the topmost surface inside the tank. Then add the two measurements together.

Figures 6 and 7 apply to various sizes of Heatec portable tanks. For your convenience, the first three columns show each level three different ways. The first column shows only inches. The second column shows feet and tenths of a foot. The third column shows feet and inches.

Some people prefer to work with feet and inches, so the third column will eliminate the need to convert inches to feet and inches. Levels shown on the pressure transmitter and on the Honeywell controller are in feet and tenths of a foot, so the second column will be more convenient for readings from these devices.

Note: Unlike vertical tanks, volumes in portable tanks are *not* in direct proportion to the levels. The volume increases or decreases at *different* rates for each change in level.

REFILL VOLUME

This is the amount of fuel you can add to a partially filled tank. It is the difference between the *net* volume (**Figure 2**) and the volume currently in the tank. It is also an indication of how many gallons have been used since the tank was last filled. This assumes that the net volume is accurate as discussed earlier. Moreover, it assumes that you are not actually using fuel from the tank while it is being refilled.

The best way to verify how many gallons a supply truck has added to refill your tank is to record the levels before and after refilling. Then convert the two levels to gallons according to **Figures 6 and 7**. The difference between the two indicates how much the supply truck added. Again, you cannot make an accurate determination if you are using fuel from the tank at the same time it is being filled.

ACCURACY

Some errors are unavoidable when measuring levels and converting them to gallons of fuel in the tank.

Several factors affect the accuracy of determining exactly how many gallons of fuel are in your tank. One factor is the amount of error in the level measurement. Another is manufacturing tolerances related to tank dimensions.

Level measurements are made several ways. One way is to simply use a measuring tape. Another way is by installing a pressure transmitter and Honeywell controller. Mechanical clock style gauges with floats are sometimes installed. In any case measurements may have errors of an inch or so. Converting less-than-perfect level measurements to gallons provides a reasonably accurate, but un-verified, number of gallons.

The actual dimensions of your tank may vary from its design diameter and length due to manufacturing tolerances. Portable tanks are currently designed with an inside diameter of 126 inches (120 inches for double wall tanks) and the lengths listed in **Figure 4**. These are the dimensions used to calculate the gallons shown in **Figures 6 and 7**. Variations in diameter and length due to normal manufacturing tolerances may cause the actual number of gallons to differ slightly from the number of gallons shown in **Figures 6 and 7** for a specific level.

In the past not all Heatec portable tanks were designed with the dimensions mentioned above. If your tank was designed with different dimensions, you should not attempt to use **Figures 6 and 7**. The gallons shown in these figures will be *significantly* different than your actual gallons. In that case, please contact Heatec for a custom-made levels vs. volume table applicable to your tank.

CHECKING YOUR PRESSURE TRANSMITTER

You should periodically verify the accuracy of the levels indicated by your pressure transmitter.

The usual way of checking that your pressure transmitter is accurate is with a measuring tape. As explained earlier, measure the distance from the inside top of the tank to the surface of the fuel. Then subtract this distance from the inside diameter of the tank (126 or 120 inches as applicable). Subtract 0.5 feet or 6 inches from the level indication shown on the transmitter. The resulting numbers should closely agree.

FIGURE 4. INSIDE DIMENSIONS				
PORTABLE TANKS WITH SINGLE WALLS				
Nominal volume (gallons)	10,000	15,000	20,000	25,000
Length (inches)	193.5	289.5	385.5	481.5
Diameter (inches)	126	126	126	126
PORTABLE TANKS WITH DOUBLE WALLS				
Nominal volume (gallons)	10,000	15,000	20,000	25,000
Length (inches)	217.5	337.5	457.5	577.5
Diameter (inches)	120	120	120	120
*The dimensions shown here apply only to the current line of Heatec tanks.				

EFFECTS OF TEMPERATURE

The information in this document is based on fuel at a temperature of 60 degrees F. The volume of fuel in your tank will change when the fuel expands or contracts as a result of temperature variations. Temperature of the fuel will vary with the ambient temperature. Its temperature can also change if a fuel pre-heater is used and heated fuel is returned to the tank.

You should make allowances for changes in volume due to temperature, *especially when filling the tank*. **Figure 2** shows the net volume for Heatec fuel tanks with an allowance of 6 inches of reserve space for expansion and an extra margin of safety.

Most ambient temperature fluctuations during a 24 hour period will have very little effect on a full tank of fuel. The temperature of the fuel will probably remain close to an average of the ambient temperatures over 24 hours. However, fuel temperatures are apt to change to a greater extent over several weeks or months, when the weather changes from one season to another.

Figure 5 shows how changes in fuel temperature affect its volume. The volumes shown for 60 degrees F correspond to the capacities of standard Heatec tanks. The temperatures should be regarded as average temperatures over a period of 24 hours.

Figure 5. How fuel volumes (gallons) vary with temperature							
30 Deg F	40 Deg F	50 Deg F	60 Deg F	70 Deg F	80 Deg F	90 Deg F	100 Deg F
10110	10161	10212	10,263	10314	10366	10418	10470
15126	15202	15278	15,355	15432	15509	15586	15664
20141	20242	20344	20,446	20548	20651	20754	20858
25158	25284	25411	25,539	25667	25795	25924	26054

FIGURE 6. SINGLE WALL TANKS LEVELS VS. GROSS VOLUMES (GALLONS) (PART 1 OF 3 PARTS)

Inches	LEVELS		10,000 GALLON TANK	15,000 GALLON TANK	20,000 GALLON TANK	25,000 GALLON TANK
	Feet/ Tenths	Feet/ Inches				
126	10.5	10'-6"	10445	15627	20809	25991
125	10.4	10'-5"	10432	15608	20784	25959
124	10.3	10'-4"	10410	15574	20738	25903
123	10.3	10'-3"	10380	15530	20680	25830
122	10.2	10'-2"	10345	15478	20611	25743
121	10.1	10'-1"	10306	15420	20533	25646
120	10.0	10'-0"	10263	15355	20447	25539
119	9.9	9'-11"	10217	15285	20354	25422
118	9.8	9'-10"	10167	15210	20254	25298
117	9.8	9'-9"	10114	15131	20149	25167
116	9.7	9'-8"	10058	15048	20038	25028
115	9.6	9'-7"	10000	14961	19922	24883
114	9.5	9'-6"	9939	14870	19801	24731
113	9.4	9'-5"	9876	14775	19675	24574
112	9.3	9'-4"	9810	14678	19545	24412
111	9.3	9'-3"	9743	14577	19411	24244
110	9.2	9'-2"	9674	14473	19272	24072
109	9.1	9'-1"	9603	14367	19131	23895
108	9.0	9'-0"	9530	14257	18985	23713
107	8.9	8'-11"	9455	14146	18836	23527
106	8.8	8'-10"	9378	14031	18684	23337
105	8.8	8'-9"	9301	13915	18529	23143
104	8.7	8'-8"	9221	13796	18371	22946
103	8.6	8'-7"	9140	13675	18210	22744
102	8.5	8'-6"	9058	13552	18046	22540
101	8.4	8'-5"	8975	13427	17880	22332
100	8.3	8'-4"	8890	13300	17711	22121
99	8.3	8'-3"	8804	13171	17539	21907
98	8.2	8'-2"	8717	13041	17365	21690
97	8.1	8'-1"	8628	12909	17190	21470
96	8.0	8'-0"	8539	12775	17011	21248
95	7.9	7'-11"	8448	12640	16831	21023
94	7.8	7'-10"	8357	12503	16649	20795
93	7.8	7'-9"	8265	12365	16465	20566
92	7.7	7'-8"	8171	12225	16279	20333
91	7.6	7'-7"	8077	12085	16092	20099
90	7.5	7'-6"	7982	11943	15903	19863
89	7.4	7'-5"	7887	11799	15712	19625
88	7.3	7'-4"	7790	11655	15520	19385
87	7.3	7'-3"	7693	11509	15326	19143
86	7.2	7'-2"	7595	11363	15131	18899
85	7.1	7'-1"	7496	11215	14934	18654

FIGURE 6. SINGLE WALL TANKS LEVELS VS. GROSS VOLUMES (GALLONS) (PART 2 OF 3 PARTS)

LEVELS			10,000 GALLON TANK	15,000 GALLON TANK	20,000 GALLON TANK	25,000 GALLON TANK
Inches	Feet/ Tenths	Feet/ Inches				
84	7.0	7'-0"	7397	11067	14737	18407
83	6.9	6'-11"	7297	10918	14538	18158
82	6.8	6'-10"	7197	10768	14338	17909
81	6.8	6'-9"	7096	10617	14137	17658
80	6.7	6'-8"	6995	10465	13935	17405
79	6.6	6'-7"	6893	10312	13732	17152
78	6.5	6'-6"	6790	10159	13528	16897
77	6.4	6'-5"	6688	10006	13324	16642
76	6.3	6'-4"	6585	9852	13118	16385
75	6.3	6'-3"	6481	9697	12912	16128
74	6.2	6'-2"	6377	9541	12706	15870
73	6.1	6'-1"	6273	9386	12498	15611
72	6.0	6'-0"	6169	9230	12290	15351
71	5.9	5'-11"	6064	9073	12082	15091
70	5.8	5'-10"	5960	8916	11873	14830
69	5.8	5'-9"	5855	8759	11664	14569
68	5.7	5'-8"	5750	8602	11455	14307
67	5.6	5'-7"	5644	8445	11245	14045
66	5.5	5'-6"	5539	8287	11035	13783
65	5.4	5'-5"	5433	8129	10825	13520
64	5.3	5'-4"	5328	7971	10615	13258
63	5.3	5'-3"	5222	7813	10404	12995
62	5.2	5'-2"	5117	7655	10194	12733
61	5.1	5'-1"	5011	7498	9984	12470
60	5.0	5'-0"	4906	7340	9774	12208
59	4.9	4'-11"	4800	7182	9564	11945
58	4.8	4'-10"	4695	7025	9354	11683
57	4.8	4'-9"	4590	6867	9145	11422
56	4.7	4'-8"	4485	6710	8935	11161
55	4.6	4'-7"	4380	6553	8727	10900
54	4.5	4'-6"	4276	6397	8518	10640
53	4.4	4'-5"	4171	6241	8310	10380
52	4.3	4'-4"	4067	6085	8103	10121
51	4.3	4'-3"	3964	5930	7896	9863
50	4.2	4'-2"	3860	5775	7690	9605
49	4.1	4'-1"	3757	5621	7485	9349
48	4.0	4'-0"	3654	5467	7280	9093
47	3.9	3'-11"	3552	5314	7076	8839
46	3.8	3'-10"	3450	5162	6874	8585
45	3.8	3'-9"	3349	5010	6672	8333
44	3.7	3'-8"	3248	4859	6471	8082
43	3.6	3'-7"	3148	4709	6271	7832

FIGURE 6. SINGLE WALL TANKS LEVELS VS. GROSS VOLUMES (GALLONS) (PART 3 OF 3 PARTS)

LEVELS			10,000 GALLON TANK	15,000 GALLON TANK	20,000 GALLON TANK	25,000 GALLON TANK
Inches	Feet/ Tenths	Feet/ Inches				
42	3.5	3'-6"	3048	4560	6072	7584
41	3.4	3'-5"	2948	4411	5874	7337
40	3.3	3'-4"	2850	4264	5678	7092
39	3.3	3'-3"	2752	4117	5483	6848
38	3.2	3'-2"	2655	3972	5289	6606
37	3.1	3'-1"	2558	3827	5097	6366
36	3.0	3'-0"	2462	3684	4906	6128
35	2.9	2'-11"	2368	3542	4717	5891
34	2.8	2'-10"	2273	3401	4529	5657
33	2.8	2'-9"	2180	3262	4343	5425
32	2.7	2'-8"	2088	3124	4159	5195
31	2.6	2'-7"	1996	2987	3977	4968
30	2.5	2'-6"	1906	2852	3797	4743
29	2.4	2'-5"	1817	2718	3619	4520
28	2.3	2'-4"	1728	2586	3443	4301
27	2.3	2'-3"	1641	2455	3269	4084
26	2.2	2'-2"	1555	2327	3098	3870
25	2.1	2'-1"	1470	2200	2929	3659
24	2.0	2'-0"	1387	2075	2763	3451
23	1.9	1'-11"	1304	1952	2599	3246
22	1.8	1'-10"	1224	1831	2438	3045
21	1.8	1'-9"	1144	1712	2280	2847
20	1.7	1'-8"	1066	1595	2124	2653
19	1.6	1'-7"	990	1481	1972	2463
18	1.5	1'-6"	915	1369	1823	2278
17	1.4	1'-5"	842	1260	1678	2096
16	1.3	1'-4"	771	1154	1536	1919
15	1.3	1'-3"	702	1050	1398	1746
14	1.2	1'-2"	634	949	1264	1579
13	1.1	1'-1"	569	851	1134	1416
12	1.0	1'-0"	506	757	1008	1259
11	0.9	0'-11"	445	666	887	1108
10	0.8	0'-10"	387	579	771	963
9	0.8	0'-9"	331	495	660	824
8	0.7	0'-8"	278	416	554	692
7	0.6	0'-7"	228	342	455	568
6	0.5	0'-6"	182	272	362	452
5	0.4	0'-5"	138	207	276	345
4	0.3	0'-4"	99	149	198	247
3	0.3	0'-3"	65	97	129	161
2	0.2	0'-2"	35	53	70	88
1	0.1	0'-1"	13	19	25	31

FIGURE 7. DOUBLE WALL TANKS LEVELS VS. GROSS VOLUMES (GALLONS) (PART 1 OF 3 PARTS)						
Inches	LEVELS		10,000 GALLON TANK	15,000 GALLON TANK	20,000 GALLON TANK	25,000 GALLON TANK
	Feet/Tenths	Feet/Inches				
120	10.0	10'-0"	10649	16524	22399	28274
119	9.9	9'-11"	10635	16503	22370	28238
118	9.8	9'-10"	10610	16464	22318	28172
117	9.8	9'-9"	10578	16414	22250	28086
116	9.7	9'-8"	10540	16355	22170	27985
115	9.6	9'-7"	10497	16288	22080	27871
114	9.5	9'-6"	10450	16215	21980	27746
113	9.4	9'-5"	10399	16136	21873	27610
112	9.3	9'-4"	10344	16051	21758	27465
111	9.3	9'-3"	10286	15961	21636	27311
110	9.2	9'-2"	10225	15866	21508	27149
109	9.1	9'-1"	10161	15767	21373	26979
108	9.0	9'-0"	10095	15664	21233	26803
107	8.9	8'-11"	10026	15557	21088	26620
106	8.8	8'-10"	9954	15446	20938	26430
105	8.8	8'-9"	9880	15332	20783	26234
104	8.7	8'-8"	9805	15214	20624	26033
103	8.6	8'-7"	9727	15093	20460	25827
102	8.5	8'-6"	9647	14970	20292	25615
101	8.4	8'-5"	9566	14843	20121	25398
100	8.3	8'-4"	9482	14714	19945	25177
99	8.3	8'-3"	9397	14582	19766	24951
98	8.2	8'-2"	9310	14447	19584	24721
97	8.1	8'-1"	9222	14310	19399	24487
96	8.0	8'-0"	9133	14171	19210	24249
95	7.9	7'-11"	9042	14030	19018	24007
94	7.8	7'-10"	8949	13887	18824	23761
93	7.8	7'-9"	8855	13741	18627	23513
92	7.7	7'-8"	8760	13594	18427	23260
91	7.6	7'-7"	8664	13444	18225	23005
90	7.5	7'-6"	8567	13294	18020	22747
89	7.4	7'-5"	8469	13141	17813	22485
88	7.3	7'-4"	8369	12987	17604	22221
87	7.3	7'-3"	8269	12831	17393	21955
86	7.2	7'-2"	8167	12673	17180	21686
85	7.1	7'-1"	8065	12515	16964	21414
84	7.0	7'-0"	7962	12355	16747	21140
83	6.9	6'-11"	7858	12193	16529	20864
82	6.8	6'-10"	7753	12031	16309	20586
81	6.8	6'-9"	7648	11867	16087	20306

FIGURE 7. DOUBLE WALL TANKS LEVELS VS. GROSS VOLUMES (GALLONS) (PART 2 OF 3 PARTS)

LEVELS			10,000 GALLON TANK	15,000 GALLON TANK	20,000 GALLON TANK	25,000 GALLON TANK
Inches	Feet/ Tenths	Feet/ Inches				
80	6.7	6'-8"	7542	11702	15863	20024
79	6.6	6'-7"	7435	11537	15639	19740
78	6.5	6'-6"	7327	11370	15412	19455
77	6.4	6'-5"	7219	11202	15185	19168
76	6.3	6'-4"	7111	11034	14957	18880
75	6.3	6'-3"	7001	10864	14727	18590
74	6.2	6'-2"	6892	10694	14496	18299
73	6.1	6'-1"	6782	10523	14265	18006
72	6.0	6'-0"	6671	10352	14032	17713
71	5.9	5'-11"	6560	10180	13799	17419
70	5.8	5'-10"	6449	10007	13565	17123
69	5.8	5'-9"	6337	9834	13330	16827
68	5.7	5'-8"	6226	9660	13095	16530
67	5.6	5'-7"	6113	9486	12859	16232
66	5.5	5'-6"	6001	9312	12623	15934
65	5.4	5'-5"	5889	9138	12387	15635
64	5.3	5'-4"	5776	8963	12150	15336
63	5.3	5'-3"	5663	8788	11912	15037
62	5.2	5'-2"	5550	8613	11675	14737
61	5.1	5'-1"	5437	8437	11437	14437
60	5.0	5'-0"	5324	8262	11200	14137
59	4.9	4'-11"	5211	8087	10962	13837
58	4.8	4'-10"	5098	7911	10724	13537
57	4.8	4'-9"	4986	7736	10487	13238
56	4.7	4'-8"	4873	7561	10250	12938
55	4.6	4'-7"	4760	7386	10013	12639
54	4.5	4'-6"	4648	7212	9776	12340
53	4.4	4'-5"	4535	7037	9540	12042
52	4.3	4'-4"	4423	6864	9304	11744
51	4.3	4'-3"	4311	6690	9069	11447
50	4.2	4'-2"	4200	6517	8834	11151
49	4.1	4'-1"	4089	6344	8600	10856
48	4.0	4'-0"	3978	6172	8367	10561
47	3.9	3'-11"	3867	6001	8134	10268
46	3.8	3'-10"	3757	5830	7903	9976
45	3.8	3'-9"	3647	5660	7672	9684
44	3.7	3'-8"	3538	5490	7443	9395
43	3.6	3'-7"	3430	5322	7214	9106
42	3.5	3'-6"	3322	5154	6987	8819
41	3.4	3'-5"	3214	4987	6761	8534

FIGURE 7. DOUBLE WALL TANKS LEVELS VS. GROSS VOLUMES (GALLONS) (PART 3 OF 3 PARTS)						
Inches	LEVELS		10,000 GALLON TANK	15,000 GALLON TANK	20,000 GALLON TANK	25,000 GALLON TANK
	Feet/ Tenths	Feet/ Inches				
40	3.3	3'-4"	3107	4822	6536	8250
39	3.3	3'-3"	3001	4657	6313	7968
38	3.2	3'-2"	2896	4493	6091	7688
37	3.1	3'-1"	2791	4331	5870	7410
36	3.0	3'-0"	2687	4169	5652	7134
35	2.9	2'-11"	2584	4009	5435	6860
34	2.8	2'-10"	2481	3851	5220	6589
33	2.8	2'-9"	2380	3693	5006	6320
32	2.7	2'-8"	2280	3537	4795	6053
31	2.6	2'-7"	2180	3383	4586	5789
30	2.5	2'-6"	2082	3230	4379	5528
29	2.4	2'-5"	1985	3079	4174	5269
28	2.3	2'-4"	1888	2930	3972	5014
27	2.3	2'-3"	1793	2783	3772	4762
26	2.2	2'-2"	1700	2637	3575	4513
25	2.1	2'-1"	1607	2494	3381	4268
24	2.0	2'-0"	1516	2353	3189	4026
23	1.9	1'-11"	1426	2214	3001	3788
22	1.8	1'-10"	1338	2077	2815	3553
21	1.8	1'-9"	1252	1942	2633	3323
20	1.7	1'-8"	1167	1810	2454	3097
19	1.6	1'-7"	1083	1681	2279	2876
18	1.5	1'-6"	1002	1554	2107	2659
17	1.4	1'-5"	922	1430	1939	2448
16	1.3	1'-4"	844	1310	1775	2241
15	1.3	1'-3"	768	1192	1616	2040
14	1.2	1'-2"	695	1078	1461	1844
13	1.1	1'-1"	623	967	1311	1655
12	1.0	1'-0"	554	860	1166	1472
11	0.9	0'-11"	488	757	1026	1295
10	0.8	0'-10"	424	658	892	1125
9	0.8	0'-9"	363	563	763	963
8	0.7	0'-8"	305	473	641	810
7	0.6	0'-7"	250	388	526	664
6	0.5	0'-6"	199	309	419	529
5	0.4	0'-5"	152	236	319	403
4	0.3	0'-4"	109	169	229	289
3	0.3	0'-3"	71	110	149	188
2	0.2	0'-2"	39	60	81	103
1	0.1	0'-1"	14	21	29	36