

HEATEC TEC-NOTE

Publication No. 5-04-122 Revised 1-31-07

Setting Barksdale pressure switch on Heatec thermal fluid heaters

Heatec currently uses Barksdale Dialmatic pressure switch CDPD2H-A80SS on all Heatec thermal fluid heaters.

Differential pressure refers to the *difference* in pressure at the inlet and outlet of the helical coil of the heater. Differential pressure is related to how fast thermal fluid is flowing through the coil.

It's extremely important to maintain adequate flow to avoid damaging the heater coil, to prevent breakdown of thermal fluid and to achieve efficient use of the heat produced by the burner.

Abnormally *low* flow can result either from blockage in the thermal fluid circuit or from leakage due to a rupture in the coil or piping, or from a pump malfunction, etc. Moreover, a fire could result if there is leakage of thermal fluid inside the heater.

Blockage is the most common problem. It is usually due to a strainer clogged by debris that the thermal fluid has picked up from the piping. This is more apt to happen upon the initial startup of the heater when there is debris left over from the manufacturing process and installation of the piping.

How the differential switches work

The Barksdale unit has two pressure differential switches in limit circuits that shut down the burner when abnormal differential pressure across the heater coil is detected. (See Figures 1 and 4). It's important to remember that both switches are *differential* switches. Both always sense the pressure *difference* between two points, the inlet of the heater coil and the outlet of the heater coil! One is normally open and is set for low pressure. The other is normally closed and is set for high pressure. Each opens or closes according to the differential pressure set on its dial.

Two pressure gauges are also used. One is on each side of the differential switch. One gauge always indicates the pressure at the inlet of the heater coil. The other always indicates the pressure at the outlet of the coil.

Do not confuse the pressure indications shown on these two gauges with coil *differential* pressure. Neither gauge alone indicates coil *differential* pressure. To determine coil differential pressure you must subtract the smaller pressure indication (value) from the larger indication (value).

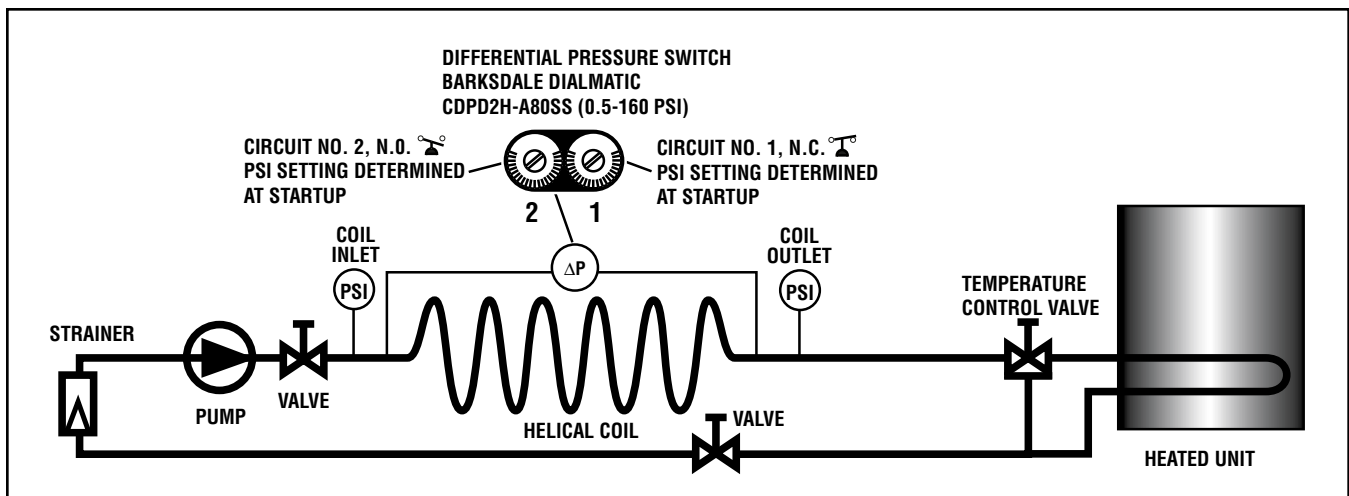

Figure 1. Heatec thermal fluid heater with Barksdale pressure differential switch.

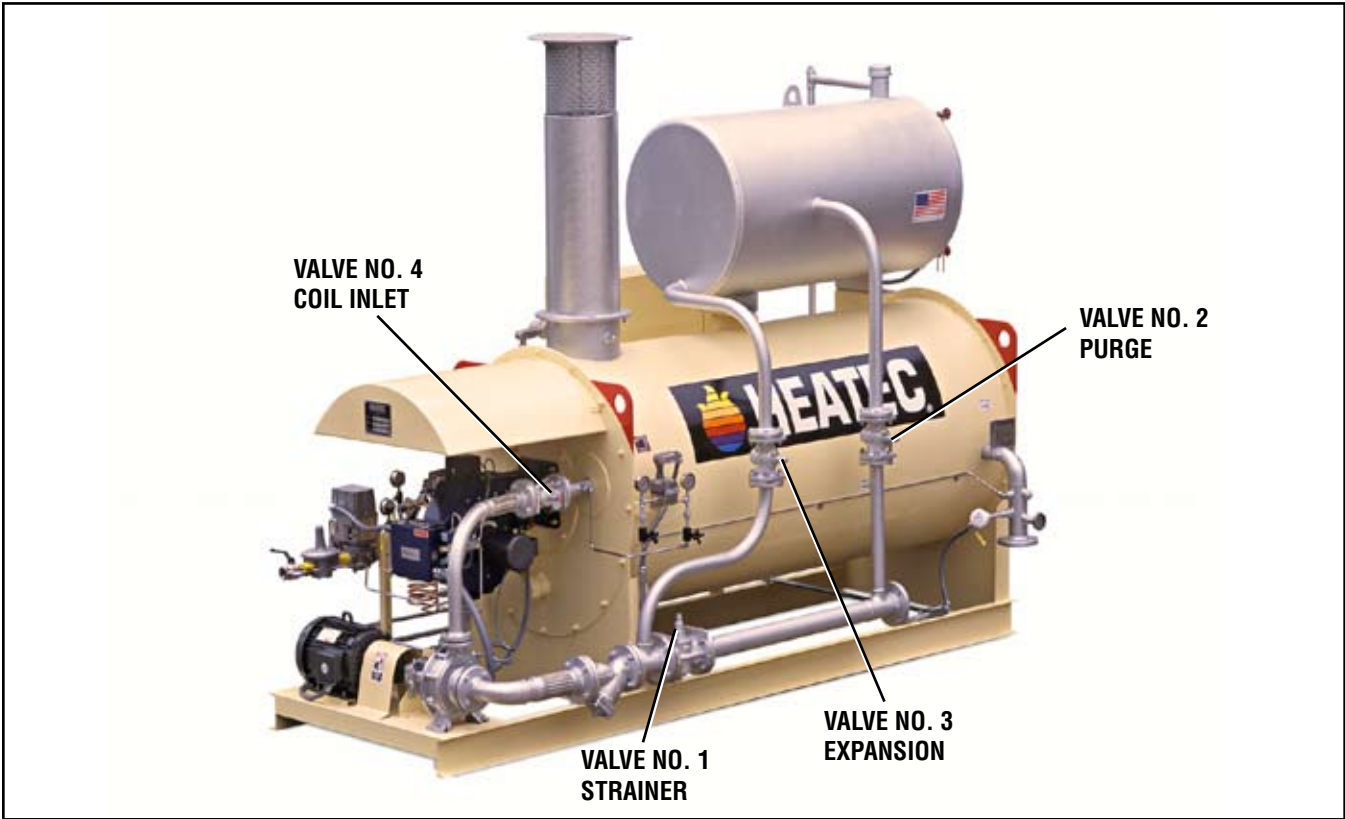

Figure 2. Heatec HCS (single line) thermal fluid heater (no side pumps).

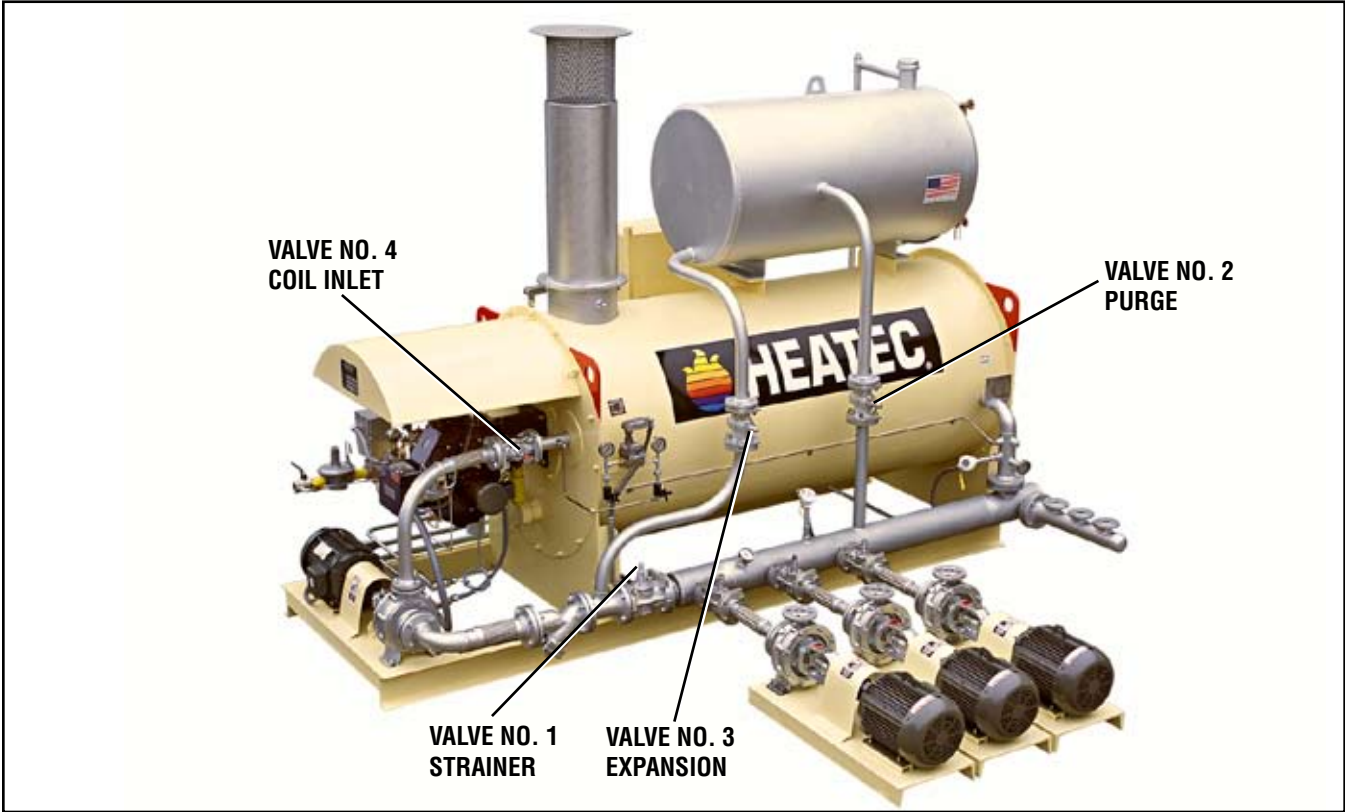

Figure 3. Heatec HC (manifold) thermal fluid heater (with side pumps).

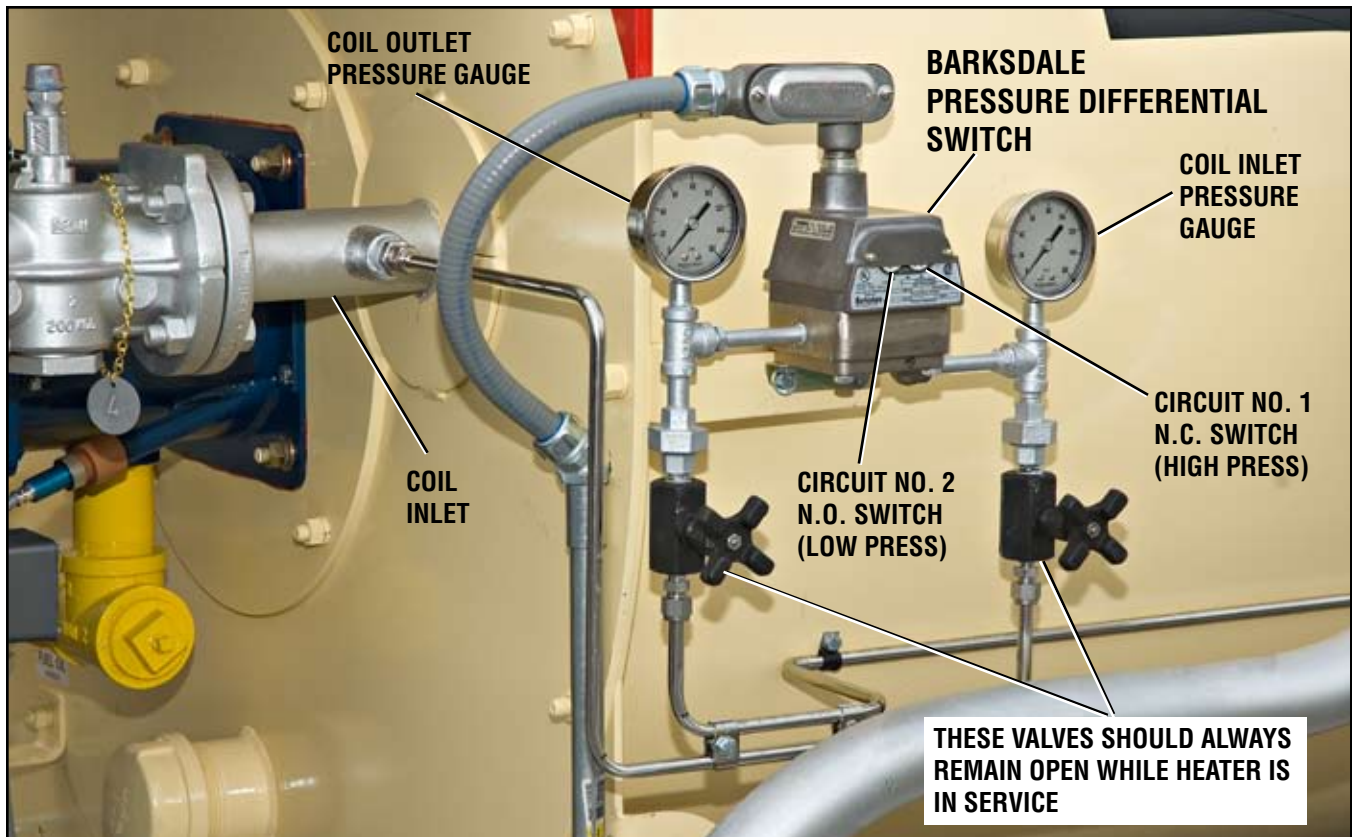

Figure 4. Barksdale pressure differential switch CDPD2H-A80SS

Pressure differentials on HC heaters

Pressure differentials for HC heaters (**Figure 3**), which are heaters with side pumps, vary according to the size of the heater. Appropriate settings for the pressure differential switches must be determined during initial startup of the heater.

Our experience indicates that most HC-120 heaters in normal operation typically produce the values shown in **Figure 5**. However, other sizes of HC heaters will have different pressure differentials.

Pressure differentials on HCS heaters

Pressure differentials for HCS heaters (**Figure 2**), which are heaters *without* side pumps) vary according to the installation and according to size of the heater. Appropriate settings for the pressure differential switches must be determined during initial startup of the heater.

Procedure for setting switches

This procedure applies to all current Heatec thermal fluid heaters, including those used in industrial facilities as well as those used in the HMA industry.

The system should be filled with thermal fluid and purged of air according to instructions in applicable Heatec documents. Bleed the two gauges (**Figure 4**) to remove air. Make sure the strainer is clean and there are no signs of leaks.

It's not necessary to run the burner to purge the system of water or moisture at this point. Accordingly, you can disregard current settings of the differential pressure switches.

Note: This procedure is for an initial startup of the heater, before the thermal fluid has been heated higher than ambient air temperature. After you make the initial settings of the differential switches, you will need to repeat this procedure while the burner is operating and while the thermal fluid is heating up. You may also need to repeat the procedure again after the thermal fluid has reached its normal operating temperature.

Figure 5. Determining settings for Barksdale pressure differential switches.

Line	INSTRUCTIONS	Typical HC-120	1st operation	2nd operation	3rd operation
1	Enter pump maximum output pressure from Step 3.	78			
2	Enter coil inlet pressure from Step 7.	60			
3	Enter coil outlet pressure from Step 8.	2			
4	Subtract line 3 from line 2. This is the coil differential pressure.	58			
5	Subtract line 4 from line 1.	20			
6	Divide line 5 by 2.	10			
7	Add lines 4 and 6. This is the setting for Circuit No. 1, N.C. switch (high).	68			
8*	Divide line 4 by 2. This is the setting for Circuit No. 2, N.O. switch (low).	29			
*Note: Line 8 revised 1-31-07. To obtain the correct setting take half of the value shown on line 4 or divide by 2—not by line 2 as previously stated.					

Perform the following steps and complete the column marked 1st operation in **Figure 5**.

Step 1. Close valves 1 and 2. Leave valves 3 and 4 open (**Figures 2 and 3**).

Step 2. Operate the thermal fluid pump.

Step 3. Enter on Line 1 of **Figure 5** the value shown on the coil inlet pressure gauge (**Figure 4**). This is the maximum output pressure of the pump. It should indicate the same psi as the coil outlet pressure gauge.

Step 4. Turn off the thermal fluid pump.

Step 5. Open valves 1 and 2. (**Figures 2 and 3**.)

Step 6. Operate the thermal fluid pump.

Step 7. Enter on Line 2 of **Figure 5** the value shown on the gauge for the coil *inlet*. (**Figure 4**.)

Step 8. Enter on Line 3 of **Figure 5** the value shown on the gauge for the coil *outlet*. (**Figure 4**.)

Step 9. Fill in Lines 4 through 8 of **Figure 5** by making the simple calculations indicated.

Step 10. Set the two dials of the Barksdale unit according to the values shown on Lines 7 and 8 of **Figure 5**.

Note: **Figure 5** has extra blank columns marked 2nd operation and 3rd operation for repeating the procedures after you begin to heat the thermal fluid, as previously noted.

After the settings have been made with the thermal fluid at normal operating temperature, allow the heater to operate for several hours under normal operating conditions to make sure the final settings do not cause it to shut down.

Time delay relays may be required

The Barksdale Dialmatic switch can cause an unintended shutdown in certain systems. This can occur in a *single line system* that has one or more temperature control valves that momentarily shut off flow when opening and closing.

We now use a time-delay relay in the heater controls of HCS (single line) heaters to prevent unintentional shutdown while a temperature control valve opens and closes. We will retrofit a time-delay relay into the controls of any existing HCS heater that experiences

Do not permanently disable the differential switch to avoid the problem. Disabling the switch will void our warranty on the helical coil.

this problem.

Time delay relays not always needed

The shutdown problem does not occur in systems that employ temperature control valves that have *proportioning* plugs. (These valves are also known as *proportional* valves.) They do *not* momentarily shut off flow when opening and closing. All temperature control valves in piping installations now performed by Heatec are *proportional* valves.

Likewise, the shutdown problem does not usually occur in heaters that have manifolds. Heaters with manifolds always maintain flow through the heater coil.

The shutdown problem does not occur in industrial applications where there are usually other provisions to maintain flow.