

HEATEC TEC-NOTE

Publication No. 9-06-179

Setting Datel display used with Heatec fuel tanks

NOTICE: This document applies to datel displays used with pressure transmitters installed August 21, 2006 and thereafter. Tec-Note 5-04-117 applies to displays on transmitters installed prior to that date.

This document provides information for setting Datel Displays DMS-20 PC-4/20S (**Figure 1**) used to indicate fuel levels in Heatec fuel tanks. The settings apply to vertical tanks up to 600 inches tall equipped with a Siemens pressure transmitter that has been setup according to Tec-Note 9-06-177 .

Displays purchased from Heatec are normally set at our factory and require no further setup. However, personnel at the hot mix plant can use these instructions to reset a display if necessary.

You will need a signal simulator, such as a Fluke 787 Processmeter, to provide outputs from 4 to 20 mA. You will also need a small screwdriver, such as a jewelers No. 0. Reset the display as follows (**See Figure 2**):

1. Disconnect existing wires from the two terminals on the back of the display.
2. Set DIP switch 2 to ON. Set all others to OFF.

3. Connect positive wire from simulator to positive terminal on display. Connect negative wire from the simulator to negative terminal on display.
4. Set the output of the simulator to 4.0 mA. Adjust potentiometer R3 on the back of the display to make the display indicate 000.
5. Reset the output of the simulator to 20.0 mA. Adjust potentiometer R7 on the back of the display to make the display indicate 584.
6. Reset the output of the simulator to 4.0 mA. Readjust R3 to make the display indicate 016.
7. Reset the simulator to 20.0 mA and make sure the display now indicates 600. If not repeat the process.
8. Disconnect the wires from the simulator and reconnect the original wires.

The display should now indicate fuel levels in inches above the bottom of the tank starting at a level 16 inches above the bottom of the tank.

Please refer to Heatec Tec-Note 9-06-177 for more information on levels and the Siemens pressure transmitter.



Figure 1. Datel display.

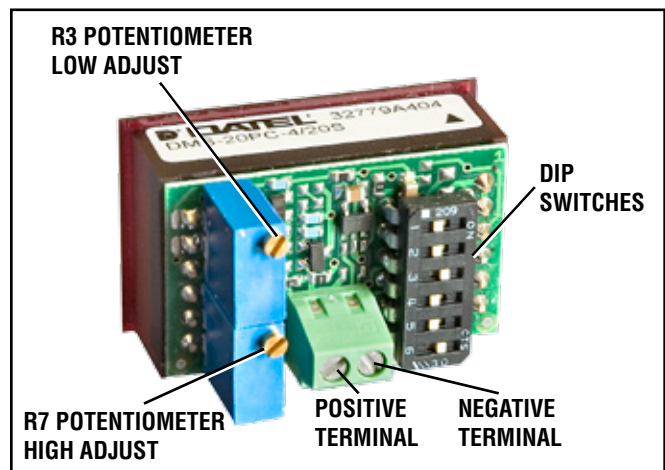

Figure 2. Controls on back of Datel display